

UNITED STATES DEPARTMENT OF AGRICULTURE
FOREST SERVICE

**SHARPENING
CROSSCUT SAWS**



ACKNOWLEDGMENT

The material in this pamphlet has been prepared after a careful reading of publications of the various saw manufacturers. All of the illustrations are either taken bodily from such publications or are adaptations of those appearing in them.

SHARPENING CROSSCUT SAWS

Setting or sharpening crosscut saws is a job for an expert, but in some isolated regions experienced filers are not available. Saws must, however, be kept in good repair. With this in mind, all material in this section has been compiled as an aid to the beginner for whatsoever value it may be to him. The expert filer who has worked out his own methods of saw filing, it is hoped, will readily grant the value and reason for the data although he might not agree in all particulars with the instructions given.

GENERAL

Crosscut saw teeth must be filed or fitted to suit the kind of timber to be cut. Shorter rakers (drags) and a flatter bevel on the teeth and a greater set is needed to cut softwood than hardwood, or dry wood. More set is also needed to cut pitchy wood than nonresinous species.

THE OPERATION

To properly fit or file a crosscut saw, the operations in the order listed are necessary. Each one is very important and calls for application of particular pains upon the part of the filer.

First—Jointing teeth.

Second—Dressing the rakers.

Third—Filing.

Fourth—Setting.

JOINTING

Jointing means to make all teeth the same length. To accomplish this, place a seven or eight inch standard bastard mill file edgeways in any universal saw tool and secure it by the thumbscrews. Place tools as shown in Figure 1 and pass the file lightly over the teeth. This will take off the high spots. Watch closely until every tooth shows that the file has touched it. Then stop. Use care to prevent any unnecessary use of the file. To have every tooth show a file mark is the object. The longer teeth will show a heavy mark, while shorter ones should show a mere trace of the file's work.

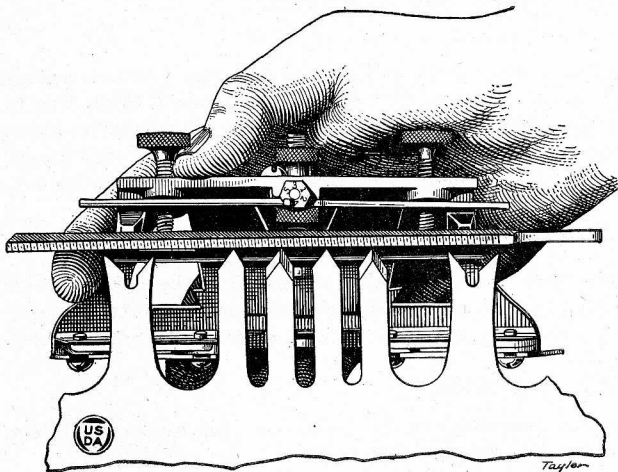

FIG. 1.—Showing position of file in saw tool in jointing cutting teeth.

Two styles of rakers are commonly used, i. e., the swaged raker and the straight raker. Figure 2 shows the method of swaging rakers. This calls for greater skill than can be expected from an inexperienced man, and since this section is prepared as a guide to inexperienced forest officers, the simpler method will be described. The latter, in fact, is equally as effective. Many of the most expert filers use it in preference to swaging. Unskilled men working without instructors had better not try the swaging method.

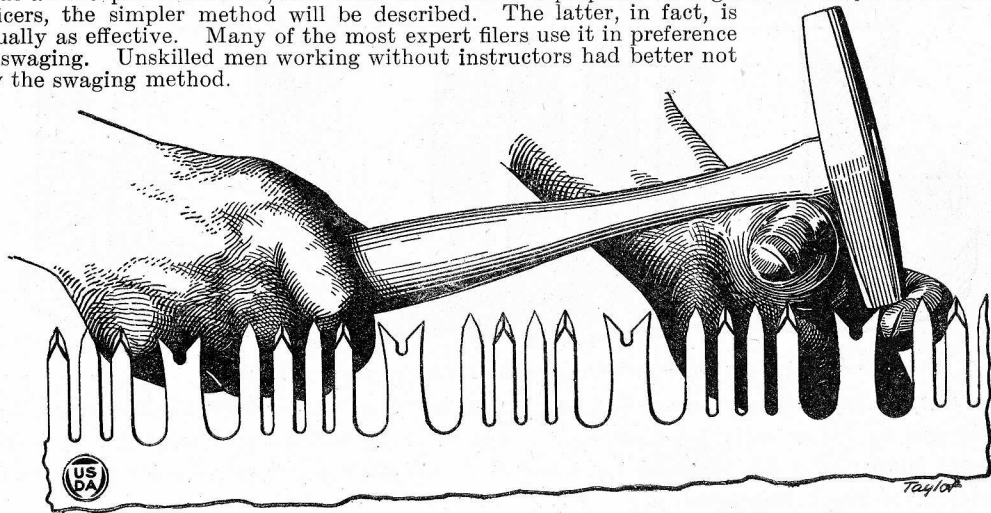

FIG. 2.—Illustrating method of swaging rakers.

AMOUNT REGULATED ACCORDING TO KIND OF
TIMBER TO BE CUT $\frac{1}{64}$ " TO $\frac{1}{32}$ " SPACE HERE

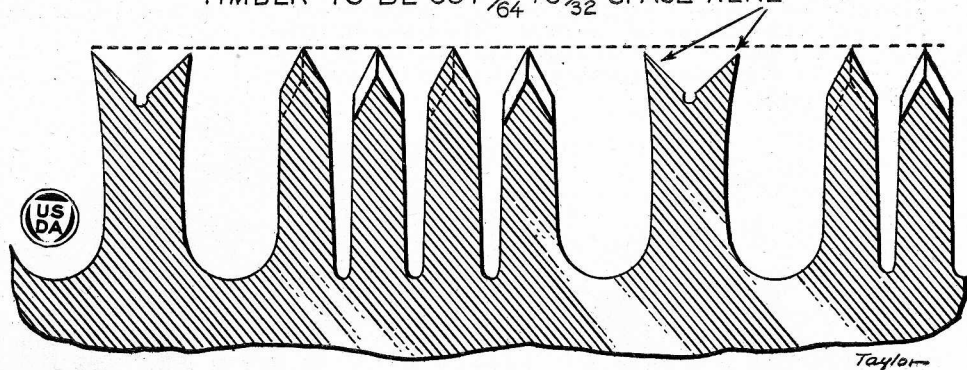

FIG. 3.—Showing difference in height of cutting teeth and rakers (drags).

Rakers should be $\frac{1}{64}$ th to $\frac{1}{40}$ th of an inch shorter than the cutting teeth for sawing hardwood; $\frac{1}{40}$ th to $\frac{1}{32}$ d of an inch for softwood. The various combination crosscut saw tools have different contrivances for adjusting the raker gauge to different heights in order to secure the differences of length mentioned.

In order to have instructions conveniently at hand for adjusting the raker seats of various combination tools commonly used and for using the tools to dress rakers, the following is given:

DRESSING RAKERS WITH SIMONDS NO. 342 CROSSCUT SAW TOOL

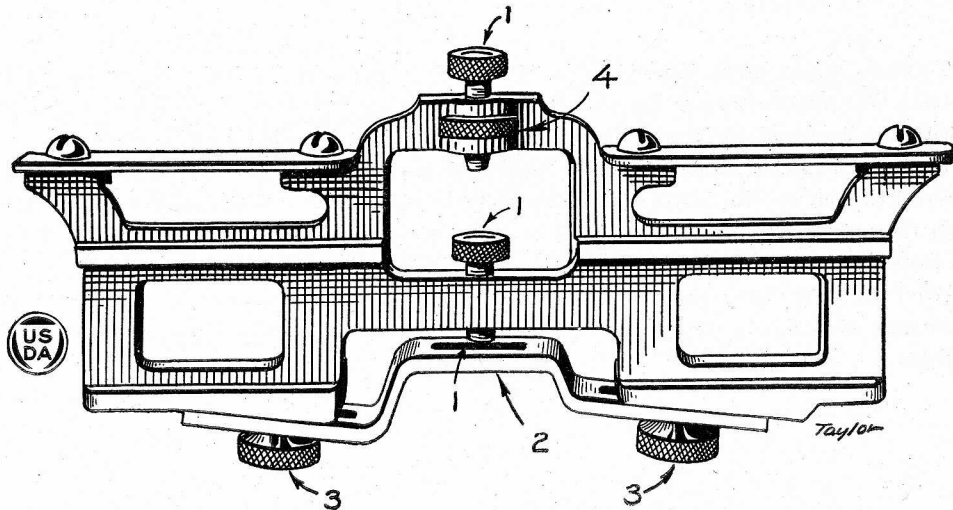

FIG. 4.—Simonds No. 342 Crosscut saw tool.

To dress rakers, place the slide (No. 2) in such position on the body of the tool that the raker teeth will project through the slot in the slide the amount desired and then file the points even with the hardened surface of the slide. This operation is called jointing the rakers. The raker teeth can be made longer or shorter by moving the slide one way or another. To move the slide loosen the screws, No. 3, which will allow slide to move freely. When the raker teeth project through the proper amount ($\frac{1}{64}$ inch to $\frac{1}{40}$ inch for hardwood; $\frac{1}{40}$ inch to $\frac{1}{32}$ inch for softwood), fasten the slide in position by tightening the screws.

After the rakers have been jointed, to check the length, the gauge screw (No. 1) can be used by tightening nut (No. 4), the screws to be held in place so as to assure uniformity of gauging throughout.

INSTRUCTIONS FOR JOINTING RAKERS WITH DISSTON IMPERIAL CROSSCUT SAW TOOL

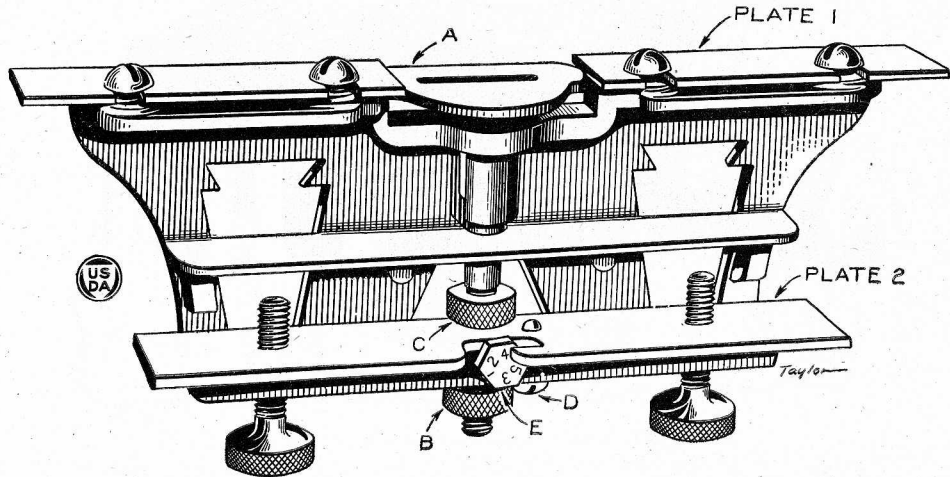

FIG. 5.—Disston imperial crosscut saw tool.

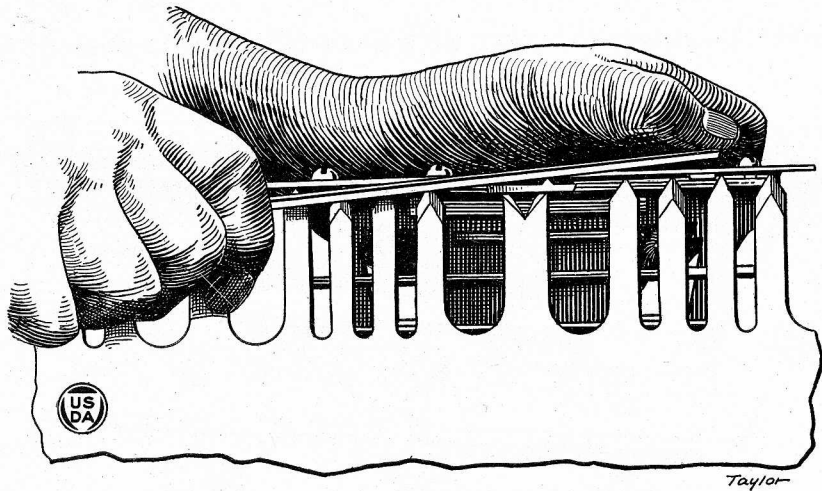

FIG. 6.—Showing position of file in jointing rakers.

Adjust plate "A" of the tool (see Figure 5) to proper height by loosening nut "C" and turning screw "B" in proper direction. When the plate is in desired position, tighten nut "C" which sets the plate permanently in place until another position might be needed. Now place

the tool on the saw over the raker (see Figure 6), and file them down flush with the steel face. The uniformity and correctness of length of drags can be readily gauged by use of the graduated gauge shown in Figure 7.

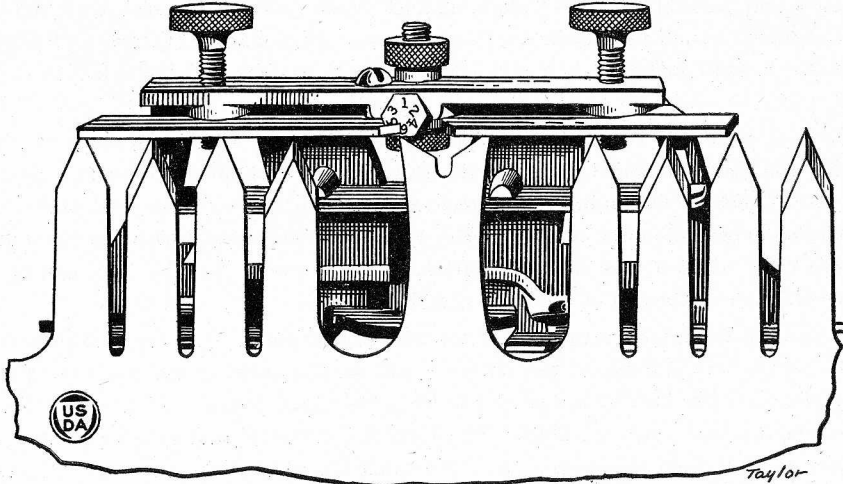

FIG. 7.—Checking height of drag with graduated gauge.

The faces of the gauge are marked from 1 to 6, the gauge being held rigid by a small round-head screw; to adjust gauge loosen the screw and turn gauge so that face opposite number wanted projects above and parallel with steel plate, against which teeth of saw rest, then tighten screw. The points of rakers should just touch the face of gauge. Face marked (1) makes raker $\frac{1}{1\frac{1}{2}}$ th inch, (2) $\frac{1}{64}$ th inch, (3) $\frac{1}{60}$ th inch, (4) $\frac{1}{40}$ th inch, (5) $\frac{1}{35}$ th inch, and (6) $\frac{1}{32}$ d inch shorter than cutting teeth.

If the steel plate "A" is set to proper position and jointing is carefully done, the rakers will be of proper and uniform height. To use the gauge above described is merely a precautionary measure. As a check to determine the correctness of the position of the steel plate "A", before using the file, its depth below the top plate (No. 1) should be compared with the distance from the face of gauge "E", when it is in desired position, to top of plate (No. 2). This can be measured with a piece of paper or the end of the file. (See Figure 5.)

After jointing the rakers, next take off the wire edge caused by jointing. Do this by a stroke with the file on the straight side of the raker. Next file the gullet of the raker from the bottom out to the point, so the heel of a square will fit in the raker gullets. Always make both raker points square across and even in height. The cutting teeth really act as markers and the rakers are in reality chisels which follow along and plow out the space between the two lines marked. Therefore, the chief thing in saw fitting is to have the rakers right.

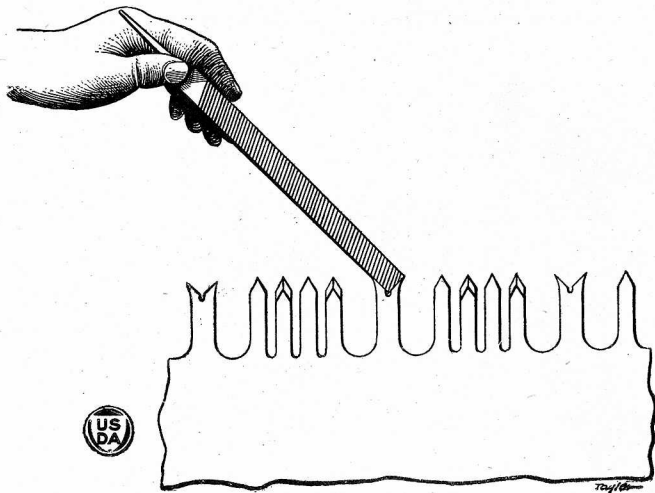

FIG. 8.—Showing proper angle of gullets of rakers.

FILING

When filing, bring each tooth to a keen cutting edge, taking care not to reduce the length of the tooth any more than is necessary to remove the marks of jointing work, then with the file in a nearly vertical position and resting evenly on the bevel, file with a precise upward stroke. This gives a keen strong point. (See Figure 9.)

Don't drag the file back on the tooth, lift it up; bastard files cut only on the out stroke. For cutting hardwood, teeth require a more abrupt bevel than to cut softwood.

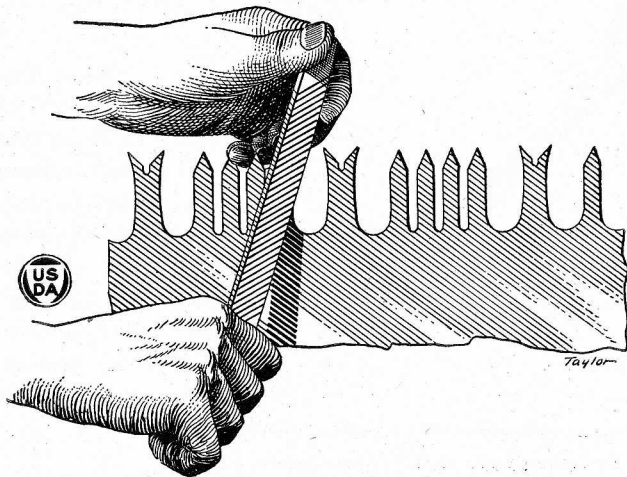

FIG. 9.—Showing correct position of file in filing cutting teeth.

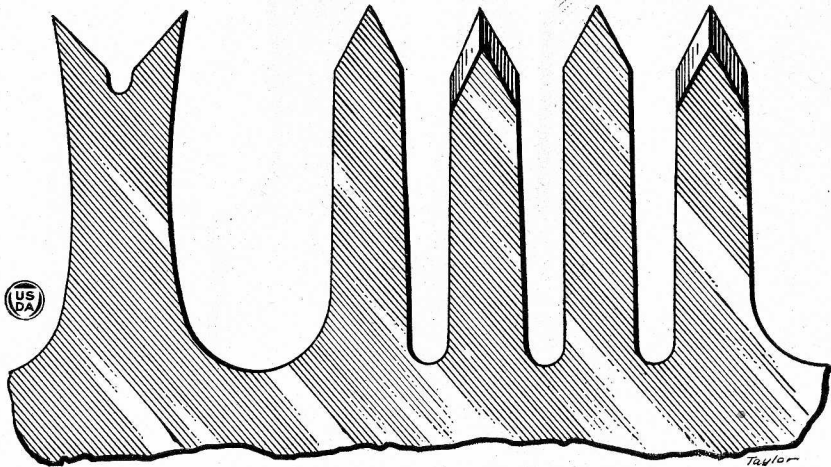

FIG. 10.—Showing good bevel of cutting teeth for softwood.

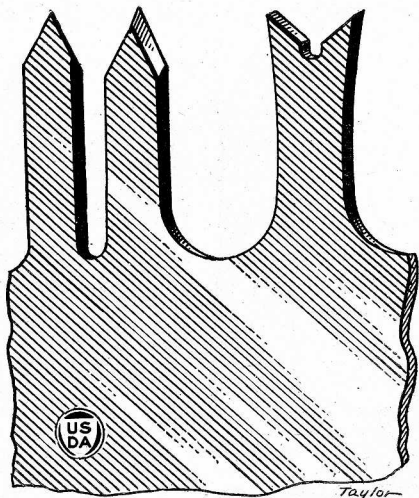

FIG. 11.—Showing bevel favored by some for softwood.

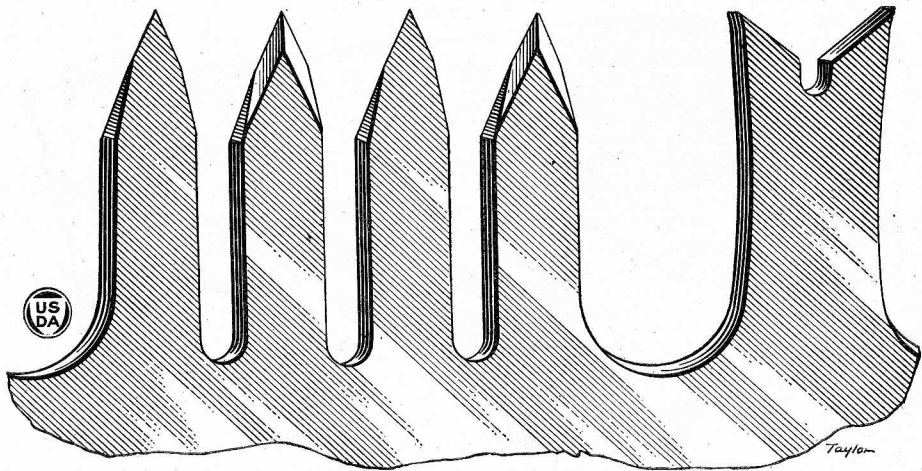

FIG. 12.—Showing correct bevel for hardwood.

SETTING

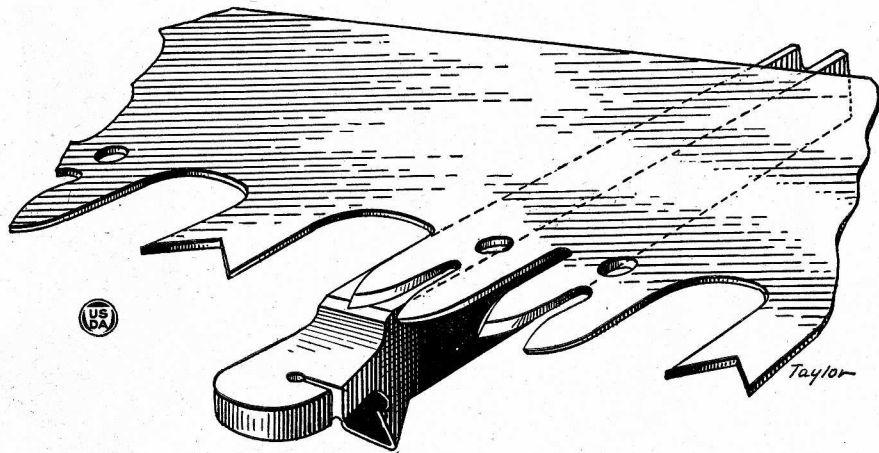
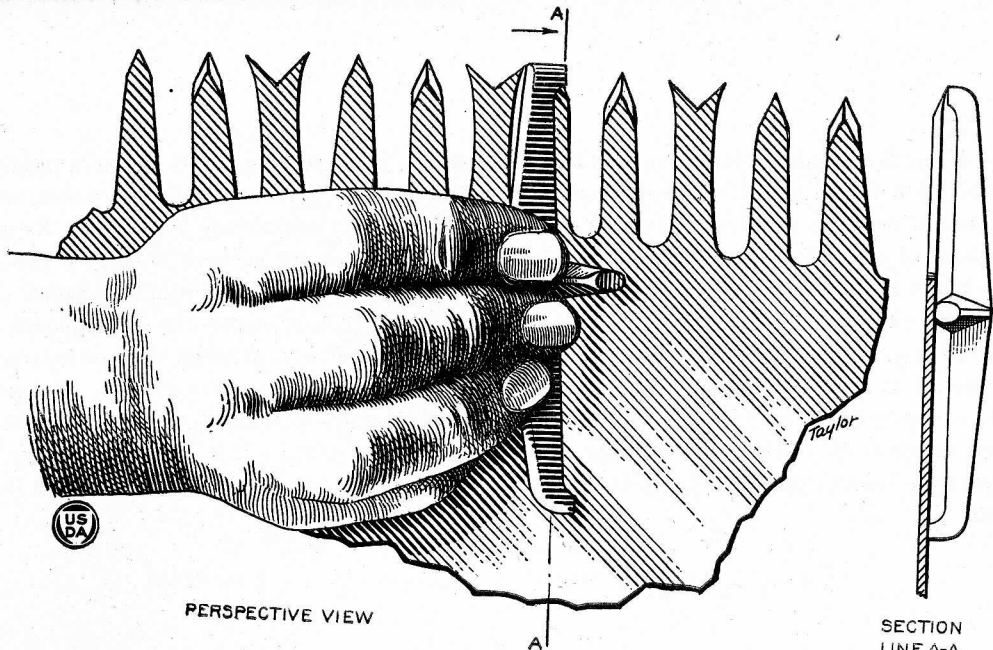

FIG. 13.—Showing saw on setting block. Note projection of tooth over setting bevel.

If the saw requires setting, lay the block or anvil on a stump, log, or block; fasten in position by striking it with a hammer over the wedge which forms a part of the bottom of the anvil, until the anvil is firmly in position. The body of the saw is then laid as shown in Figure 13. Extend the point of each tooth over the shoulder about one-quarter inch, as pictured, then give two or three blows with a light hammer. Strike the tooth always about one-quarter inch from point. It is very important that the "set" should be perfectly uniform, that is, exactly the same amount of set to all teeth. This can be tested by the use of set gauge. The amount of set required is largely determined by the kind of timber to be cut and the manner in which the saw is ground. For softwood it should be about $\frac{1}{40}$ th inch (or equal to about one or two thicknesses of ordinary writing paper) on each side of the blade. If wood to be cut is pitchy or spongy, it may be necessary to increase the amount of set to $\frac{1}{32}$ d inch on each side of the saw. For hardwood, about $\frac{1}{64}$ th inch is right.



PERSPECTIVE VIEW

SECTION
LINE A-A

FIG. 14.—Showing set gauge in use.

To test the set, place the gauge as shown in Figure 14. Now hold the spring set in right hand. (This may be an anvil with a slot in it or a hammer with a slotted peen, as shown in Figure 15.)

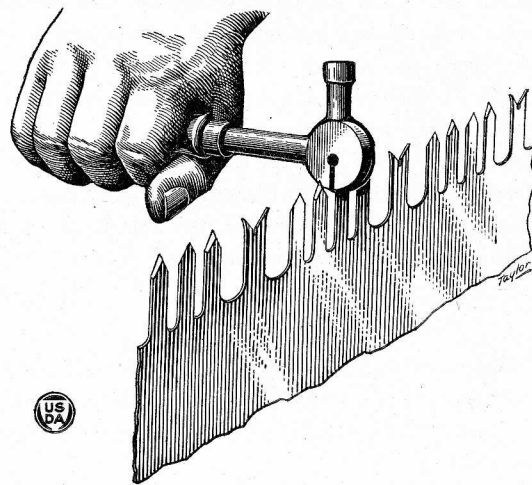

FIG. 15.—Showing spring set in use.

If the tooth has too little set, spring the tooth from you, with the spring set, being sure that the point of the tooth projects into clearance hole at the bottom of the slot in the set's head. If the tooth has too much set, reverse the operation.

If the allowance for set on the gauge is not what is wanted, this can be quickly made anything desired by filing one or the other of the working points.

The spring set is only to be used to correct the work coming from the anvil. At best, on modern saws, an attempt to use a spring set is fraught with great danger of breaking teeth. In using it, even to regulate or to correct work coming from the anvil, an inexperienced man must *exercise great care* lest he injures the saw rather than improves it.

CAUTION

The teeth must be kept even and points must be sharp and smooth. A rough edge point will break off in hard grain or knots just as surely as a freshly-ground ax will crumble or nick if used without whetting. Rakers must be shorter than the cutting teeth so as to plow out all the wood cut by the cutting teeth.

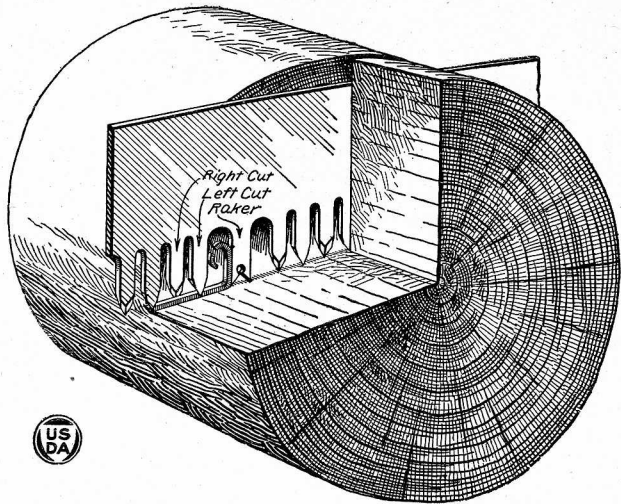

FIG. 16.—Showing action of cutting teeth and drag.

ADDITIONAL COPIES
OF THIS PUBLICATION MAY BE PROCURED FROM
THE SUPERINTENDENT OF DOCUMENTS
GOVERNMENT PRINTING OFFICE
WASHINGTON, D. C.

AT
15 CENTS PER COPY

PURCHASER AGREES NOT TO RESELL OR DISTRIBUTE THIS
COPY FOR PROFIT.—PUB. RES. 57, APPROVED MAY 11, 1922